

First Laser Excitation of the ${}^4\text{He } 1^1S\text{-}2^1P$ Resonance Line at 58 nm

K. S. E. Eikema, W. Ubachs, W. Vassen, and W. Hogervorst

*Department of Physics and Astronomy, Laser Centre Vrije Universiteit, De Boelelaan 1081,
1081 HV Amsterdam, The Netherlands*

(Received 15 June 1993)

We have observed the $1^1S\text{-}2^1P$ resonance line of ${}^4\text{He}$ at 58.4 nm (linewidth 0.3 cm^{-1}) in a laser-atomic-beam experiment. The coherent radiation is produced by fifth-harmonic generation of UV light from a frequency-doubled, pulsed dye laser at 584 nm in a pulsed expansion of acetylene gas. The frequency of the fundamental radiation is calibrated against the iodine absorption spectrum, resulting in a transition frequency of $171\,134.89(3)\text{ cm}^{-1}$. From this value a Lamb shift for the ground state of $+1.38(3)\text{ cm}^{-1}$ is extracted, in good agreement with the theoretical value of $+1.3745\text{ cm}^{-1}$.

PACS numbers: 32.30.Jc, 12.20.Fv, 42.65.Ky

Level energies of the two-electron helium atom can nowadays be calculated with advanced computational methods to high precision [1-4]. In these calculations quantum electrodynamics (QED) shifts are, as in the case of the hydrogen atom, important. In the helium case two-electron contributions to the Lamb shift, which reduce the single-electron shifts, introduce an extra complexity to the calculations. Especially for 1^1S states, where both electrons have a large overlap, this contribution becomes large and attributes up to 10% to the total Lamb shift [1]. Nonrelativistic level energies and relativistic corrections can be calculated accurately [1,3,4] so that precise measurements of transition frequencies, involving low-lying 1^1S or 1^1P states, allow for the extraction of QED contributions to these energies. In a recent series of experiments Sansonetti and Gillaspay [5] and Lichten, Shiner, and Zhou [6] followed this procedure for the 2^1S state of ${}^4\text{He}$. Using single-frequency cw tunable dye lasers they accurately determined its binding energy to a few parts in 10^{10} . After a recent accurate evaluation of the Bethe logarithm [2] the experimental binding energy of the 2^1P state is in agreement with calculations at the 10^{-5} cm^{-1} level. $O(\alpha^4)$ contributions (α is fine-structure constant), expected at this 10^{-5} cm^{-1} level, have not yet been calculated.

The Lamb shift of the 1^1S state of helium and the two-electron contributions to this shift are an order of magnitude larger than in any other state (calculated to be $+1.3745$, respectively, -0.1404 cm^{-1} [1,2]). This makes a study of the ground state most challenging and an accurate measurement of its binding energy would provide a stringent test for theory. The most recent calculation [2] predicts an energy of $-198\,310.66774\text{ cm}^{-1}$. As in the 2^1S case $O(\alpha^4)$ contributions, expected to contribute at most 0.001 cm^{-1} , are not yet included. However, the high frequencies involved in transitions from the ground state ($>170\,000\text{ cm}^{-1}$) hampered accurate measurements thus far because narrow band, tunable laser sources in the short wavelength range below 60 nm were not available. The most accurate value for the ground state binding energy is already 35 years old. In a classical emission experiment Herzberg [7] measured the

wavelength of the first two members of the ${}^4\text{He}$ principal series ($1^1S\rightarrow 2^1P$). An absolute accuracy of 0.15 cm^{-1} was stated for the 1^1S binding energy. More recently Baig *et al.* [8] measured transition energies (with an accuracy of 0.16 cm^{-1}) for the principal series n^1P for $n > 10$ in a photoabsorption experiment using synchrotron radiation.

In this Letter we report the observation of the ${}^4\text{He } 1^1S\rightarrow 2^1P$ resonance line at 58.4 nm using coherent, tunable and narrow band extreme ultraviolet (XUV) laser radiation and an atomic beam. The XUV radiation was produced by fifth-harmonic generation of the UV light from a frequency-doubled pulsed dye laser operating in the visible near 584 nm. This scheme allows for a direct and accurate comparison with iodine frequency standards in this wavelength range. The production of coherent XUV radiation below 100 nm using nonlinear up-conversion techniques of high-power pulsed laser light is now well established [9-11]. Tunable XUV radiation (with a bandwidth of 9 cm^{-1}) at a wavelength as short as 66 nm has been produced using pulsed lasers in the nanosecond range [12]. We believe the present work to be the first example of the production and application of narrow band tunable XUV radiation below 60 nm.

We use a pulsed dye laser (Quanta Ray PDL 3), operating on the dye Rhodamine B, which is pumped by the green output of an injection-seeded Nd:YAG laser (Quanta Ray GCR 4). The tunable visible output near 584 nm, which is also used for calibration purposes, is frequency doubled in a KD*P crystal. UV and visible light are separated using dichroic mirrors. Next the UV pulses near 292 nm with peak energy of 45 mJ and duration of about 3-4 ns are focused with a 15 cm lens in an expanding pulsed gas jet for nonlinear up-conversion. The gas nozzle is mounted inside a differentially pumped vacuum setup; the generated short-wavelength radiation is transmitted from the nozzle chamber through a small hole into the interaction chamber. The beams of UV, third-harmonic ($\lambda \approx 97\text{ nm}$) and fifth-harmonic ($\lambda \approx 58\text{ nm}$) light spatially overlap. We used C_2H_2 gas as the nonlinear medium. The number of photons is estimated to be at least 10^4 per laser shot. In the interaction

chamber the diverging laser beams perpendicularly intersect a pulsed beam of helium seeded in krypton (25% He and 75% Kr). The helium atoms are excited by the 58 nm light to the 2^1P state and subsequently ionized with the UV light profusely present (1 XUV+1 UV photoionization). Helium ions are extracted from the interaction zone by a small electric field (25 V/cm) and detected with an electron multiplier. A schematic of this setup is shown in Fig. 1. A more detailed description of the apparatus in conjunction with third-harmonic generation and molecular spectroscopy can be found elsewhere [13].

A typical recording of the $^4\text{He } 1^1S \rightarrow 2^1P$ resonance line at 58.4 nm is shown in Fig. 2. Also shown are the simultaneously recorded iodine absorption spectrum and the transmission peaks of a quartz etalon (free spectral range 0.25 cm^{-1}). Each data point in the 2048 channel spectrum is averaged over twenty laser shots, thus reducing shot-to-shot fluctuations. The linewidth of the observed resonance is $0.34(3) \text{ cm}^{-1}$ in the XUV, mainly determined by the dye laser linewidth of 0.065 cm^{-1} . From the divergences of the XUV and atomic beams a residual Doppler broadening of 0.02 cm^{-1} is estimated. The helium resonance line was fitted by a Voigt profile, whereas the I_2 lines were fitted by Gaussians. The lines labeled 924 and 920 in the I_2 atlas [14] were found to be symmetric in our experiment and were used for calibration. The iodine spectrum was recorded with pulse energies at the nJ level, where saturation broadening or laser-induced shifts can be neglected. The transmission peaks of the etalon were used to linearize the dye laser scan. Convenient for future calibration is the near coincidence of the helium transition with the Doppler broadened iodine absorption doublet 921 and 922 (see

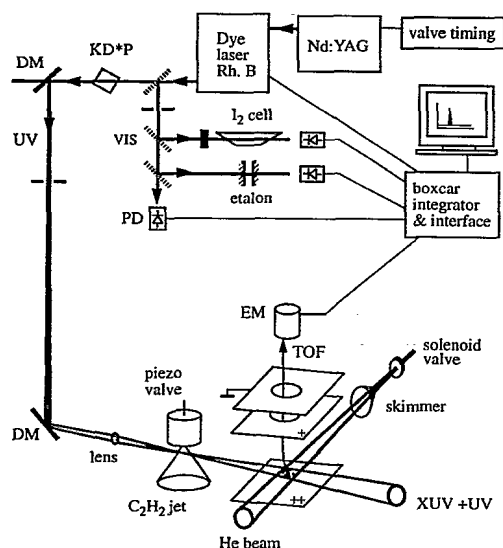

FIG. 1. Schematic of the experimental setup for XUV laser spectroscopy. DM: dichroic mirror; EM: electron multiplier; TOF: time of flight.

Fig. 2).

We carefully investigated a possible systematic error introduced by a nonperfect perpendicular alignment of laser and atomic beam. The velocity of the helium atoms in the expansion of a beam of helium seeded in krypton [velocity 480(100) m/s] and one of pure helium [1200(300) m/s]. In this way a small mismatch was observed, which resulted in a correction of 0.03 cm^{-1} in the resonance position. A value for the transition frequency of $171\,134.89 \text{ cm}^{-1}$, with a statistical error of 0.02 cm^{-1} when averaging over several spectra, is found. This error contains both the statistical error in the determination of the He-resonance line and in the I_2 absorption lines. Systematic uncertainties, due to ac and dc Stark effects or by frequency chirp of the laser [15], are smaller than 0.01 cm^{-1} . The uncertainty in the iodine atlas, given to be 0.001 cm^{-1} (1 standard deviation) [14], results in an additional systematic error of 0.01 cm^{-1} in our measurement. Combining all these unrelated errors gives a result of $171\,134.89(3) \text{ cm}^{-1}$, in good agreement with the measurement of Herzberg [7], $171\,135.04(15) \text{ cm}^{-1}$.

Using the accurately known energy of the 2^1P state of $-27\,175.772\,34(14) \text{ cm}^{-1}$ [16], which is in agreement with calculations up to the 10^{-4} cm^{-1} level, the energy of the ^4He ground state immediately follows: $-198\,310.66(3) \text{ cm}^{-1}$. This value may be compared to

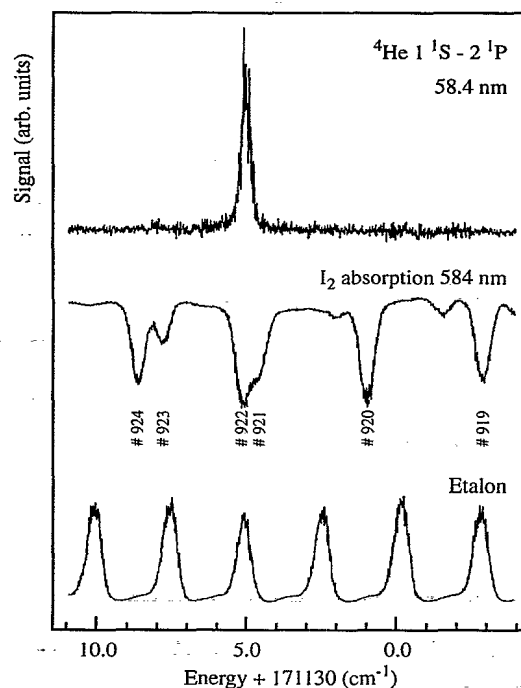

FIG. 2. The $1^1S \rightarrow 2^1P$ resonance line of ^4He at 58.4 nm recorded by 1 XUV+1 UV photoionization in the seeded beam. Also shown is part of an I_2 absorption spectrum in the visible as well as a Fabry-Pérot spectrum. We used the lines labeled 920 and 924 in the iodine atlas [14] for calibration.

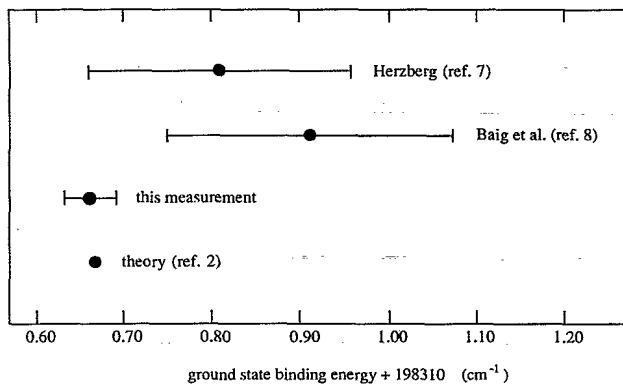

FIG. 3. Comparison of experimental and theoretical values for the binding energy of the ${}^4\text{He } 1^1\text{S}$ ground state. The uncertainty for the theory is estimated to be on the order of 0.001 cm^{-1} .

the results of the synchrotron experiments of Baig *et al.* [8] on the higher levels of the n^1P Rydberg series. From a fit of energies, derived from their wavelength measurements (accuracy 0.16 cm^{-1}), to calculated energies using Martin's formula [17] for the n^1P quantum defects we deduce a value for the ionization potential of $198310.91 \text{ cm}^{-1}$. The three experimental values for the 1^1S binding energy together with a value recently calculated by Baker *et al.* [2] are shown with error bars in Fig. 3. Combining our transition energy, the 2^1P level energy and a calculation of the 1^1S level energy not including QED effects ($-198312.04224 \text{ cm}^{-1}$ [1,4]) an experimental value of $+1.38(3) \text{ cm}^{-1}$ is found for the Lamb shift of the ${}^4\text{He } 1^1\text{S}$ state. The QED calculation of this shift contains both one-electron and two-electron contributions and leads to a value of $+1.3745(10) \text{ cm}^{-1}$ [1,2]. The two-electron part of the Lamb shift is calculated to be -0.1404 cm^{-1} [1] and its existence is clearly demonstrated in our measurement.

Our goal for the near future is to improve the accuracy in the frequency of the ${}^4\text{He } 1^1\text{S}-2^1\text{P}$ transition by at least an order of magnitude and to include a measurement on ${}^3\text{He}$. The experimental resolution can be considerably increased by incorporating pulsed amplification of narrow band cw dye laser light. The use of cw light will also allow for Doppler-free saturated absorption spectroscopy in the iodine absorption cell. An absolute experimental accuracy of 0.001 cm^{-1} in the XUV requires a 10^{-4} cm^{-1} (3 MHz) accuracy in the visible. For this purpose it will be necessary to calibrate the relevant I_2 lines to at least this level of accuracy. Furthermore, the influence of systematic shifts will have to be analyzed thoroughly. In particular shifts related to frequency chirp in the pulsed amplification of cw light [15] may become important. The influence of this effect might, e.g., be studied on accurately known transition frequencies in the hydrogen atom. An interesting possibility is to use the Ly_γ line of hydrogen at 97.3 nm for this purpose. The frequency of this Ly_γ line is almost equal to $\frac{2}{3}$ of the frequency of the

${}^4\text{He } 1^1\text{S}-2^1\text{P}$ transition. The frequency difference in the visible is only 23.8 cm^{-1} . When producing 58.4 nm radiation by fifth-harmonic generation of 292 nm we also efficiently generate the third harmonic at 97.3 nm. This line then may serve to test our iodine calibration setup as well.

In conclusion, we have measured in a laser-atomic-beam experiment the binding energy of the 1^1S ground state of ${}^4\text{He}$ with an accuracy of 0.03 cm^{-1} , thereby directly confirming the importance of two-electron contributions to the Lamb shift. Improvements, on which we are working now, may push this accuracy to better than 0.001 cm^{-1} . This will enable detailed confrontation with theoretical calculations having similar accuracy.

We thank Jacques Bouma for his skillful assistance in the construction of the experimental setup and gratefully acknowledge financial support of the Foundation for Fundamental Research on Matter (FOM), which is part of the Netherlands Organization for the Advancement of Research (NWO). We are grateful to Jon Baker and John Morgan for making available their calculated value of the Lamb shift prior to publication.

- [1] G. W. F. Drake, Nucl. Instrum. Methods Phys. Res., Sect. B **31**, 7 (1988).
- [2] J. D. Baker, R. C. Forrey, J. D. Morgan III, and R. N. Hill, Bull. Am. Phys. Soc. **38**, 1127 (1993); J. D. Baker, R. C. Forrey, M. Jeziorska, and J. D. Morgan III (to be published).
- [3] J. D. Baker, D. E. Freund, R. N. Hill, and J. D. Morgan III, Phys. Rev. A **41**, 1247 (1990).
- [4] G. W. F. Drake and A. J. Makowski, J. Opt. Soc. Am. B **5**, 2207 (1988).
- [5] C. J. Sansonetti and J. D. Gillaspay, Phys. Rev. A **45**, R1 (1992).
- [6] W. Lichten, D. Shiner, and Z. Zhou, Phys. Rev. A **43**, 1663 (1991).
- [7] G. Herzberg, Proc. R. Soc. London A **248**, 309 (1958).
- [8] M. A. Baig, J. P. Connerade, C. Mayhew, G. Noeldeke, and M. J. Seaton, J. Phys. B **17**, L383 (1984).
- [9] G. Hilber, A. Lago, and R. Wallenstein, J. Opt. Soc. Am. B **4**, 1753 (1987).
- [10] R. H. Page, R. J. Larkin, A. H. Kung, Y. R. Shen, and Y. T. Lee, Rev. Sci. Instrum. **58**, 1616 (1987).
- [11] A. Balakrishnan, V. Smith, and B. P. Stoicheff, Phys. Rev. Lett. **68**, 2149 (1992).
- [12] Y. Hirakawa, A. Nagai, K. Muraoka, T. Okada, and M. Maeda, Opt. Lett. **18**, 735 (1993).
- [13] P. F. Levelt, W. Ubachs, and W. Hogervorst, J. Chem. Phys. **163**, 263 (1992).
- [14] S. Gerstenkorn and P. Luc, *Atlas du spectre d'absorption de la moleculle de l'iode entre 14800-20000 cm⁻¹* (CNRS, Paris, 1978); S. Gerstenkorn and P. Luc, Rev. Phys. Appl. **14**, 791 (1979).
- [15] M. S. Fee, K. Danzmann, and S. Chu, Phys. Rev. A **45**, 4911 (1992).
- [16] C. J. Sansonetti, J. D. Gillaspay, and C. L. Cromer, Phys. Rev. Lett. **65**, 2539 (1990).
- [17] W. C. Martin, Phys. Rev. A **36**, 3575 (1987).